

LOC		DIST		REVISIONS			
P	LTR	DESCRIPTION	DATE	DWN	APVD		
D		REVISED PER ECO-06-014732	13NOV06	KW	DC		

- △ MATERIAL:  
HOUSING: NYLON, UL94V-0 (COLOR - NATURAL, COLOR OF PARTS MAY VARY).  
CONTACTS: 0.25 THK COPPER ALLOY.
- △ CONTACT FINISH: 0.003 MIN THK TIN-LEAD OVER 0.00127 MIN THK NICKEL OVER ENTIRE CONTACT.
- △ CONTACT FINISH: 0.00076 MIN THK GOLD PLATE ON PIN MATING SURFACE, 0.003 MIN THK TIN-LEAD PLATE ON SOLDER TAIL, ALL OVER 0.00127 MIN THK NICKEL BASE PLATE.
- 4. SOLDER TAIL MEETS AMP SOLDERABILITY SPECIFICATION 109-11-2.
- 5. MATES WITH SIMILARLY PLATED AMP-DUAC™ POWER CONNECTOR RECEPTACLE HOUSINGS/SOCKET CONTACTS.
- △ RIBS ON FOUR CORNERS OPTIONAL.
- △ AMP LOGO AND MATERIAL ID MAY BE LOCATED ON EITHER LONG SIDE OF PART.
- △ SIZE, SHAPE OR STYLE OF THIS FEATURE MAY VARY.
- △ CONTACT FINISH: 0.003 MIN THK TIN OVER 0.00127 MIN THK NICKEL OVER ENTIRE CONTACT.
- △ CONTACT FINISH: 0.00076 MIN THK GOLD PLATE ON PIN MATING SURFACE, 0.003 MIN THK TIN PLATE ON SOLDER TAIL, ALL OVER 0.00127 MIN THK NICKEL BASE PLATE.

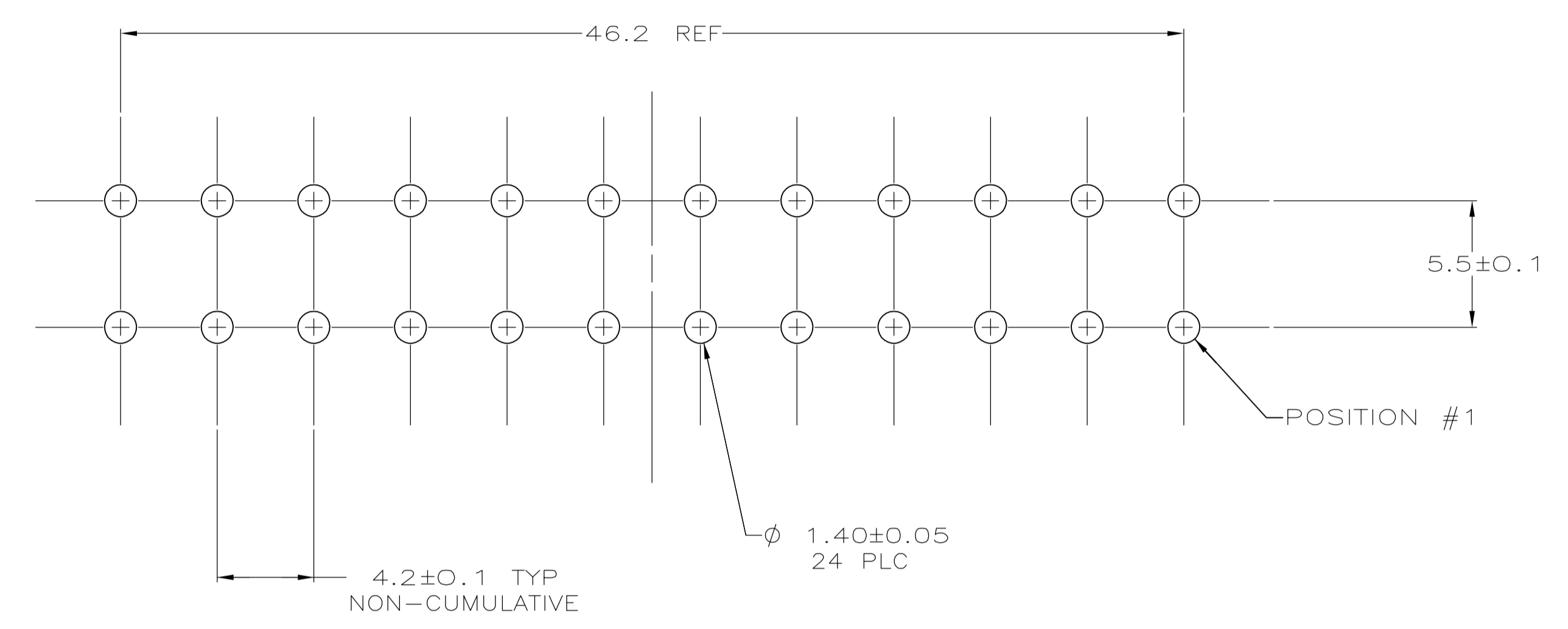

RECOMMENDED MOUNTING HOLE PATTERN FOR 1.78 MAX THICK P.C. BOARD COMPONENT SIDE SHOWN

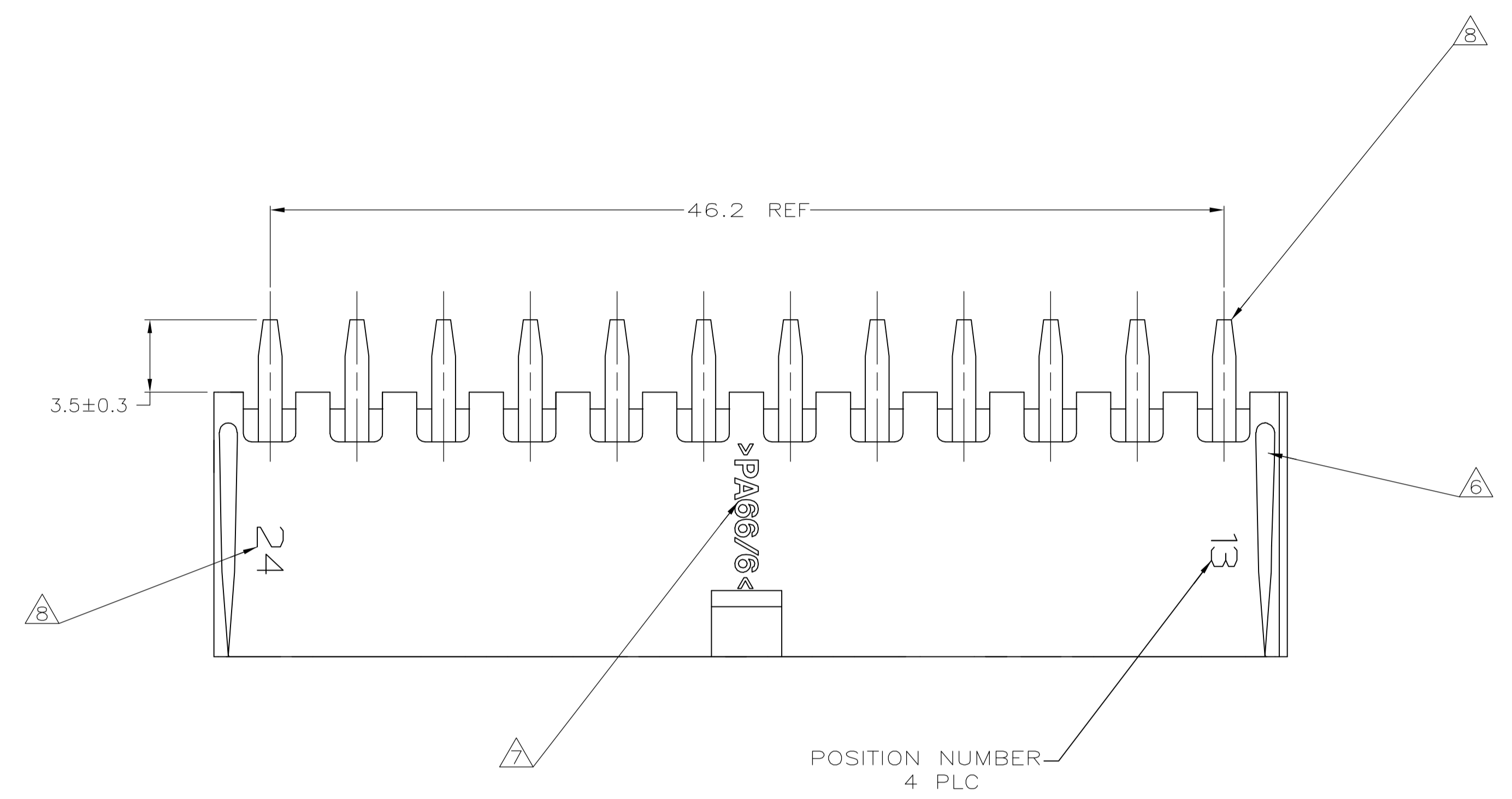
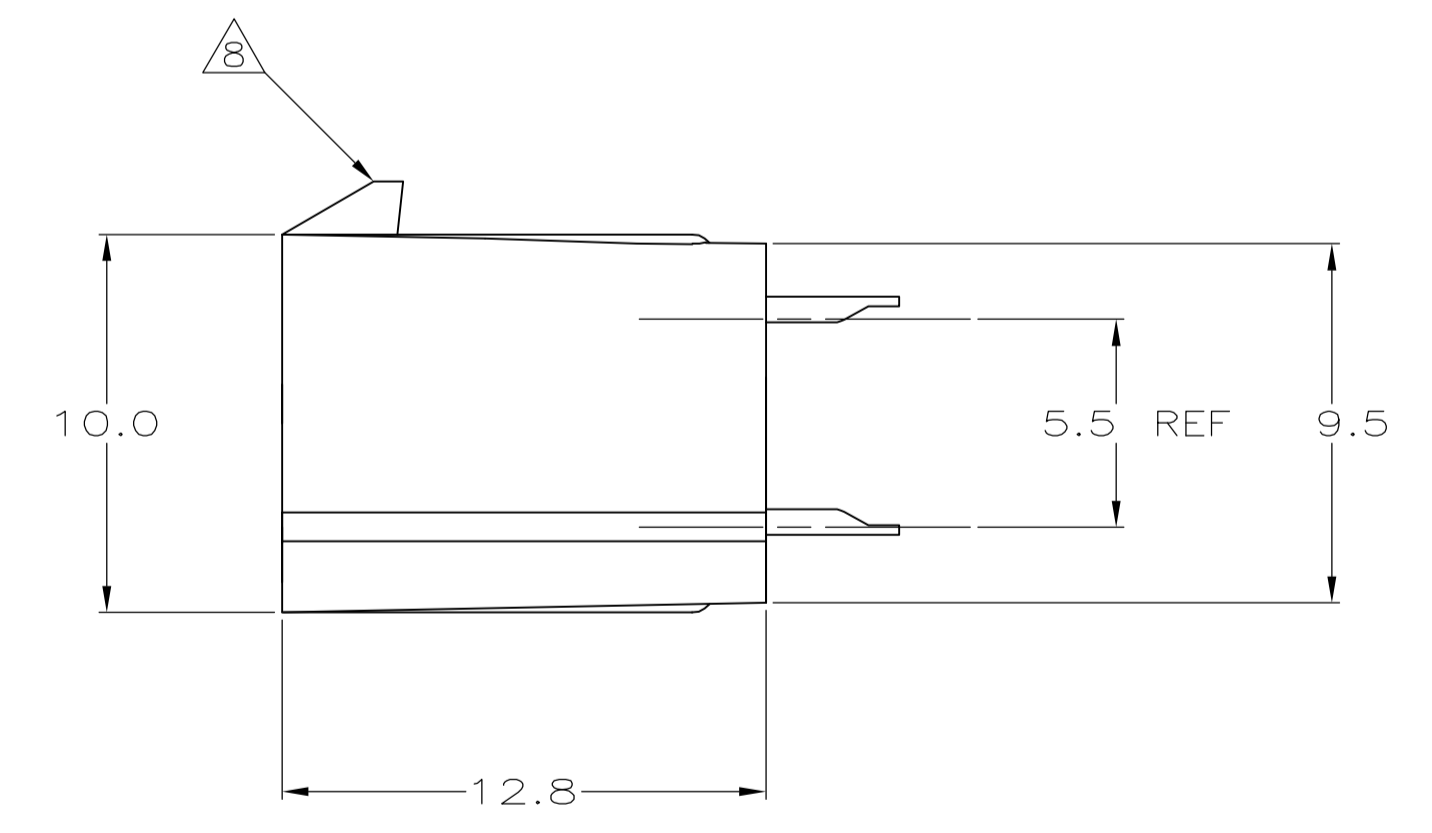
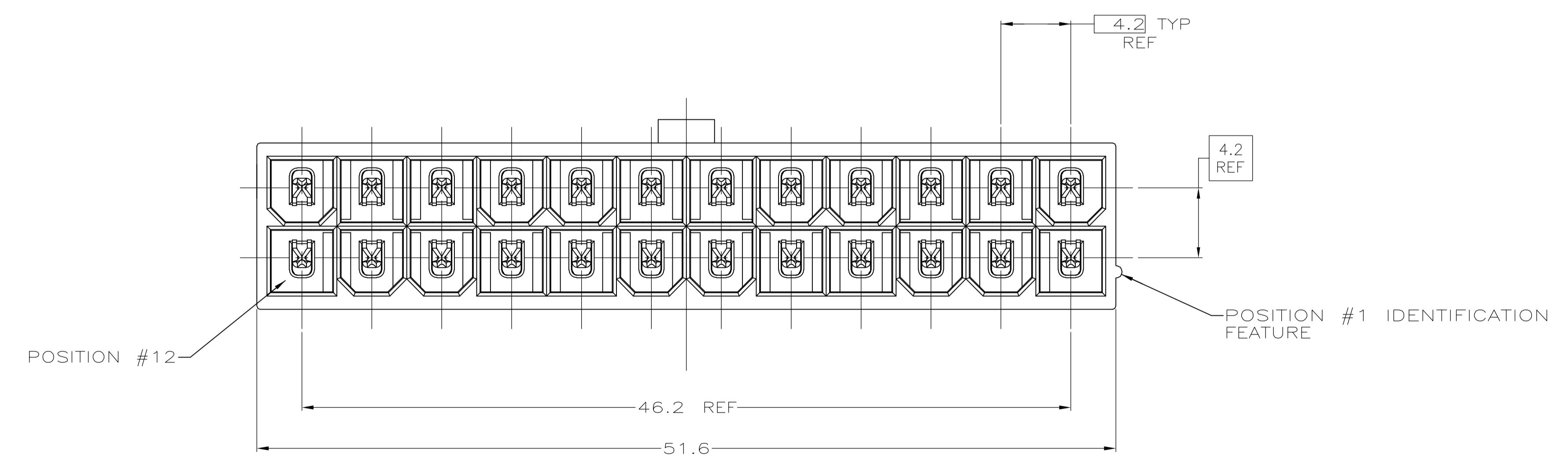

SUPERSEDED BY 1-794494-2  
 SUPERSEDED BY 1-794494-1

△ 1	△ 10	△ 1	△ 1	1-794494-2
△ 1	△ 9	△ 1	△ 1	1-794494-1
△ 1	△ 3	△ 1	△ 1	794494-2
△ 1	△ 2	△ 1	△ 1	794494-1
MATERIAL	FINISH	MATERIAL	COLOR	PART NO

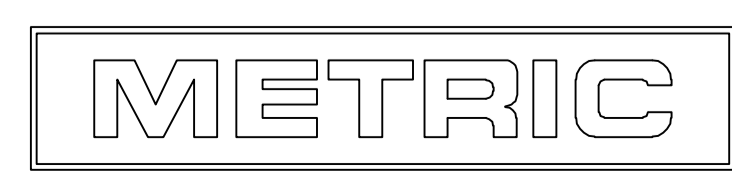

THIS DRAWING IS A CONTROLLED DOCUMENT.

DIMENSIONS: mm	TOLERANCES UNLESS OTHERWISE SPECIFIED:	DIN R VESTAL 6-11-98	APVD C CASH 6-11-98	NAME
0 PLC ± -	1 PLC ± 0.2	CHK R SWING 6-11-98	PRODUCT SPEC 108-1699	ASSEMBLY, HEADER, VERTICAL, 24 POSITION, W/ DRAIN HOLES, 94V-0, AMP-DUAC(TM)
2 PLC ± 0.13	3 PLC ± -		APPLICATION SPEC	SIZE CASE CODE DRAWING NO
4 PLC ± -	ANGLES ± ± 0.50°			A1 00779 C=794494
MATERIAL SEE TABLE	FINISH SEE TABLE	WEIGHT	CUSTOMER DRAWING	RESTRICTED TO
			SCALE 5:1	SHEET 1 OF 1 REV D

Tyco Electronics Corporation  
 Harrisburg, Pa 17105-3608